

MESA Microwave Corporation

Motorized Step Zoom Lens

MMC-MFLO-178

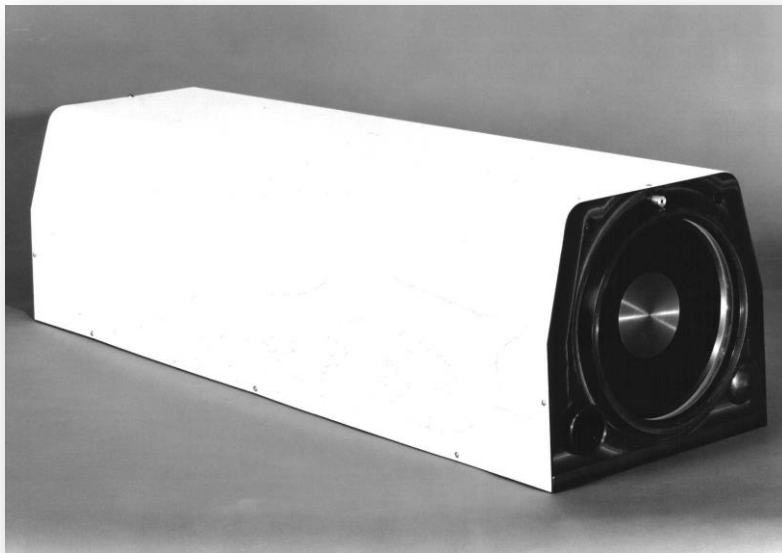

MMC AC
11/20/2003

MMC-MFLO-178 Multi Focal Length Optical System

Product Specifications

The MMC-MFLO-178 Multi Focal Length Optical System is a fully motorized, parfocusing; microprocessor controlled Maksutov Cassegrain Catadioptric Optical system with a clear aperture of 178 mm and a base focal length of 2400 mm at F/13.5. It is the most rugged and sophisticated long range surveillance lens available in the medium aperture market today. It is able to read license plates at 2.5 km and identify ships at 20 km. It is available in both a permanent site fully integrated system or a rapid deployment stand-alone configuration for mounting on customer supplied equipment. Its optional accessories give it versatility and usefulness that can be customized to meet any individual requirement. It will have state of the art electronics based on the Pentium processor and will be modular designed for easy upgrades. Each unit will come with hardware that will allow it to be controlled locally from a lap top computer's Com port or modem for longer distances Tele-communication. The software will be a Windows 95/98 and Visual Basic based platform. The keyboard and mouse will be used to access the command menus.

The MMC-MFLO-178 system comes equipped to connect to any standard video camera with C mount lens thread and will support most CCD formats. Camera is purchased separately. The system is equipped with five selectable focal lengths and filters. The internal optical components and baffling system have been designed to maximize light transmission and minimize all optical aberrations to increase overall system performance to unprecedented 1/6 wave PV minimum. The internal mechanics allow this unit to tolerate high G loads while maintaining boresight accuracy at each focal length. The enhanced mechanics provide for a rapid focal length and focus transition when in the Par focal mode, generally not to exceed 1 second. The system software will have the ability to control or monitor features such as Time/Date, Temperature, Enclosure Pressure, Multi camera switcher, Automatic light control (ALC), Wide field target acquisition finder camera, automatic sun sensor, heat/ cooling control, lens cap, Pan/Tilt, communication, and video camera control functions. Some cameras will require special or adapted software and hardware.

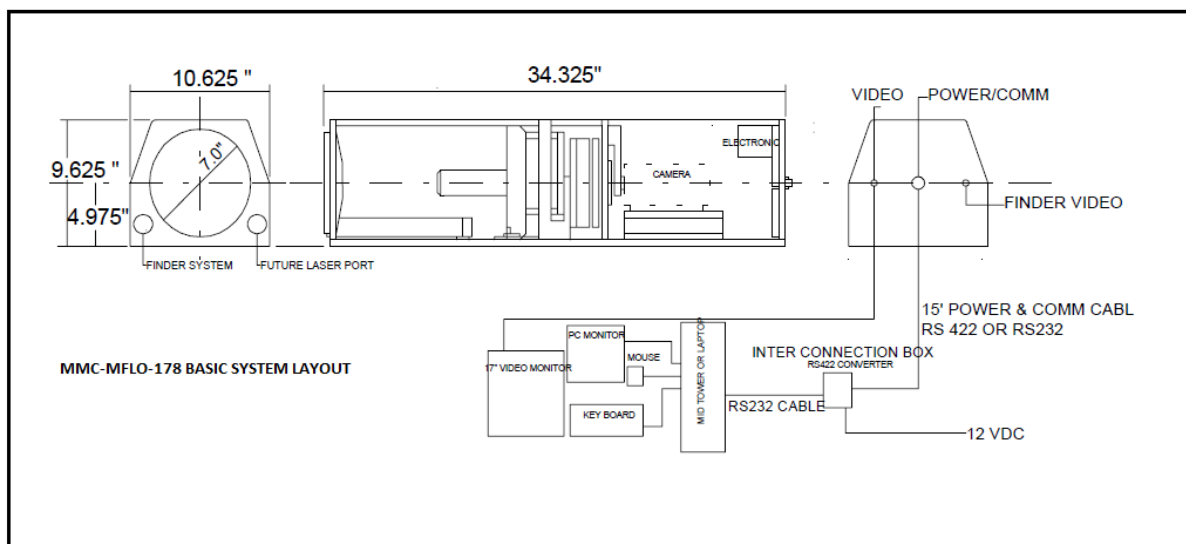

Additional Options:

- CCD Camera
- Automatic Light Control (ALC)
- Wide field target acquisition finder
- 2 Camera switching stage
- Dual head camera switching control
- Environmental Enclosure
- Environmental motorized lens cap
- Environmental heater/cooler
- Pan/Tilt
- Video frame grabber integration
- Video Transmission site to site

Optical Specification:

Working Range:	75 meters to Infinity
Resolution:	0.7 arc seconds
Format:	Diffraction limited 18 mm @ 2400 mm EFL
Clear Aperture:	178 mm
Design Type:	Maksutov Cassegrain

Corrector:	BK 7, magnesium fluoride AR coated
Primary:	Pyrex, aluminium coated, SiO over coated
Auxiliary Lens:	Achromatic, magnesium fluoride AR coated
EFL'S	900 mm, 1450 mm, 2400 mm, 4000mm 4.44: 1 zoom ratio
Optional	6000 mm
Filters:	Schott colored glass, 400 nm, 450 nm, 650 nm, 750 nm long pass filters.
Light Control Filter:	Bk7 optical glass. Neutral density 0 - 2.5. Inconel coated
Baffling:	Helix, knife-edge stop rings and anti reflective painted

Mechanical Specification:

Barrel Section:	Machined from solid aluminium stock and black anodized.
Focus:	Transiting mirror design. Mirror housed in Aluminium cell. 3 linear bearings With precision ground matched shafts. 2 pillow block precision bearings and matching rails, precision ball nut and screw drive. Variable speed DC servo motor with encoder.
Turret Section:	Lens and filter 140-mm (5.5-inch) Ø solid aluminium spur gear. Machined and anodized. Bronze bushings and roller thrust bearings on ½ inch Ø stainless steel shaft. Four coloured 38-mm Ø filters and lens in a spring-loaded adjustable bore sighting cell. Stepper motor and direct tooth belt drive. Electronic plunger solenoid lens wheel position lock for boresight accuracy. Opto sensor position placement with individual flags and feedback for error correction.
Light Control	Variable neutral density light control unit. Two Inconel coated linear filters mounted on two pillow block linear slides and motor controlled from user interface. Bk7 optical glass coated to provide neutral density 0 - 5.0.
Cover:	Aluminium black anodized form 1/16th inch thick cover skin.
Finish/Hardware:	All exterior surfaces black anodized. All hardware stainless steel. Polane paint can be added. Black, white or beige is standard. Custom colours can be specified.
Mounting:	¼ -20 or 3/8 -16 mounting holes on bottom of plate. Custom pattern and sizes available to meet your specific requirements.
Dimension:	34.3 inches long 9.8 inches tall 10.7 inches wide
Weight:	85 pounds
Power:	12VDC @ 5 amp
Communication:	RS 232 or RS 422, Windows 95/98

Optional equipment:

Wide Field Finder:	Internal 265mm integrated finder system with small B/W CCD camera.
Sun Sensor:	Automatic sun sensor to protect main system CCD camera. A small photocell and housing located on front plate of MMC-MFLO-178 will sense proximity to the sun and its intense light. It will engage a solenoid shutter to monetarily block optical path.
Automatic light control:	Automatic light control electronic circuit with manual override. This add on electronic module will allow for automatic compensation due to changing lighting conditions. The adjustable gain setting in auto mode is controlled from user interface.
Camera Switcher:	Motorized precision dual position switching platform for two-camera operation. Controlled from user interface. This unit is black anodized, ruggedized aluminium construction with precision linear bearings, DC servomotor and end of travel limit stopping indicators.
Enclosure:	Environmentally sealed aluminium fabricated lightweight enclosure. This unit includes a 10 inch coated optical protective flat, .5 PSI two way pressure relief valve, O - ring and gasket seals, internal electronic solenoid valve and pressure sensor combination to control internal pressure, brass pressure fitting, sealed BNC connectors and sealed round Bendex connector for power and communications. All exterior surfaces are black anodized, polane painted with clear overcoat. All hardware is stainless steel. Polane white paint is standard. Custom colors can be specified. 46.6 inches long 13.25 inches tall 13.25 inches wide 47 pounds
Peltier cooler/heater:	This thermoelectric device (Nema 4X rating) can be integrated into the enclosure to provide temperature regulation while maintaining the sealed integrity of the enclosure. The cooler unit has an internal preset thermostat to turn on cooler at 35° C. Optional user interface setting control will allow user to set the system software to monitor the temperature set values against the internal temperature and automatically control unit. Requires 24VDC to operate. An optional Heating element can be added to regulate low

Motorized lens cap:	temperatures. The heating unit will have an internal preset thermostat to turn on heater at 10° C. A heavy duty motorized lens cap can be installed in front of the protective optical window to protect it against severe weather or when system is not in use. Controlled from user interface.
Pan and tilt:	Heavy duty Pan and Tilt unit to provide accurate placement and motion of MMC-MFLO-178 unit. It is a High Mass low profile weatherized design for permanent installations. All control functions are from the Console Program. See following picture and specification sheet.

Motorized Heavy Duty Altitude/Azimuth Mount

The Altitude/Azimuth mount is a heavy-duty motorized unit designed to provide high pointing accuracy and stability under adverse environmental conditions. Built on a large ball bearing platform for azimuth positioning with a rugged dual fork altitude mounting, it features a low profile wind and water resistant package designed for position control of larger optical packages. Packaged DC Servo motors, drivers and on board CPU makes it compatible with MMC-MFLO-178-control systems fully automated computer based software. Operation on PC systems with Windows 95 and 98 using a standard RS-422 converter connected to the PC Comm port. This is the ideal mount for tower and ground mounted observation of horizon oriented activity. Consult our applications engineering for special requirements concerning operator control.

Mechanical:

Azimuth:

56 cm (22") diameter platform with integrated perimeter ball bearing thrust load suspension (64-8mm balls). Single row ball bearing axial load bearing, tongue and groove perimeter seal with silicone grease. Supplemental lip rain gutter seal.

Altitude:

Double fork cradle design with center platform width 33.7 cm (13.25"). Altitude axis levels with optical axis and instrument center of gravity. Two heavy-duty rollers thrust bearings and o-ring seals.

Drives:

Azimuth:

Zero backlash Harmonic drive with PMI high torque DC servo pancake motor and encoder combination. 1 to 1 gear and belt combination connect the harmonic drive and DC servo motor to drive the azimuth from the center hub assembly which houses the Harmonic drive incased over sized roller bearings. +/-150 degrees total excursion.

Altitude:

Precision oversized lead screw and matching ball nut with tangent lever arm for position control. High torque DC servomotor with precision gear head. Optical encoder mounted directly on motor axis. A total excursion +/-15 degrees.

Positioning Accuracy and speeds:

.01 degrees for both axis.

Azimuth: 15° / sec max to .01° / sec

Elevation: 2° / sec max to .01° / sec

Position Limits and azimuth brake:

Each axis has end of travel limits with auxiliary backup hard limit deflection. Azimuth has fixed anti over travel hard stop. This axis also has two (2) heavy-duty electro magnetic spring loaded brakes assembles to hold position when the azimuth is not in motion

Physical:

Finish:

Standard anodized aluminium, available with Polane finish in black and white colors standard. Consult MesaMW for special color requirements.

Mounting Platform:

Standard platform with 3/8-16 threads for all mounting cradles. Special bolt patterns available on request.

Electrical:

24 volts DC @ 20 amp

Payload:

55 kg. Max. Heavier payload capability available on request.

Weight:

54 kg. Complete with motors

Overall dimensions:

Diameter:	56 cm
Overall Height:	30.6 cm to top of fork arms
Height to Altitude rotational axis:	25 cm
Base Mounting:	(6) 1/2-13 NC

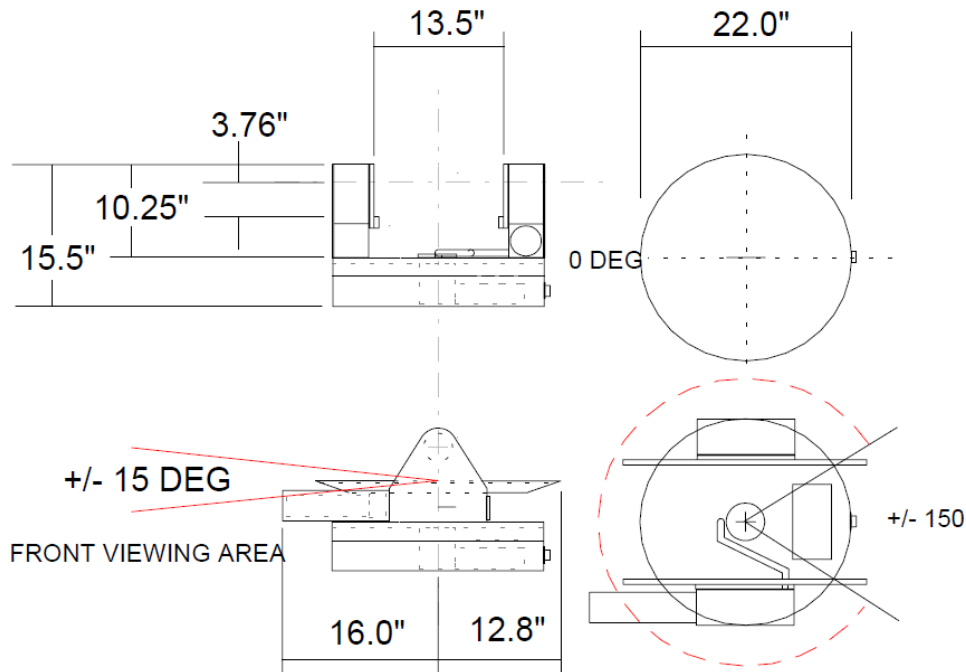

MMC-MFLO-178 Surveillance System Over View

Introduction

Mesa MW announces the development of an advanced surveillance system, the MMC-MFLO-178, designed to combine optical and electronic capability with a high level of control by proprietary software programs. This system includes the most advanced multi-focal length instrument available for border, harbor and coastal surveillance. It offers a highly reliable user interface, with the range and flexibility to utilize the optical system fully. It is also designed to take full advantage of future enhancements, which will be developed on a modular basis.

Description of New System

The MMC-MFLO-178 will provide continuous status reporting to the user interface. In addition to the display of all basic functions, the user will be able to access information such as COM, voltage, temperature and pressure. Builtin self-tests and results can be run from the user interface. A separate de-bug window provides a display of all onboard functions and current status.

Optically, O-ring mounted primary optics and newly designed auxiliary optics increase overall performance and transition speed. The built-in manually controlled Light Control hardware and display software will increase ability to acquire images and correct camera over-exposure, thus providing enhanced video. An optional camera control section will allow the use of the serial-controlled cameras. A code control library will allow each camera function to be controlled from the user interface. Please consult MesaMW for information about serial controlled cameras.

The new user interface is any Pentium (133Mhz min.) based PC with Windows 95,98 that has a serial port with the console software installed. Communications and control interface will be via RS-422 at the controller and MMC-MFLO-178. This will give the largest overall performance range (4000 feet) and will increase system communications speed. The system will require an RS 232 to RS 422 opto-isolated converter to connect to the serial port of the PC, or an opto-isolated internal RS 422 card to be installed in the PC.

If greater distance is required to control system, a modem (33.3-min.) will have to be installed in the PC at the MMC-MFLO-178 location. This PC must be as defined above no more than 4000 feet from MMC-MFLO-178 unit. This PC will have to be configured to work as a remote server with a dedicated phone line. High-speed (ISDN) data lines should be used to increase reliability and to allow for option video transmission via phone line. In addition, a two channel (min.) video frame grabber can be integrated into PC at MMC-MFLO-178 location to allow user to snap, store, enhance, save and retrieve images. This option must be installed to allow extended

system control via high-speed modem. A high-speed modem and frame grabber must be installed and configured in the remote receiving PC to receive incoming data and video images. The second-generation (upgraded) console control software will allow for smooth integration of two incoming images to be displayed on screen while maintaining control of the MMC-MFLO-178 remote system. (The video transmission can be done on standard phone lines, but may encounter jumpy display motion.)

Since applications will vary, adaptations of the basic system will be provided on an individual basis. The selection of CCD camera/cameras will vary for each requirement. MesaMW can provide or the end user may have to provide the camera for integration into the final system.

The new SZ 182 lens and Control system will consist of the following hardware:

MMC-MFLO-178 mechanical and optical hardware

- Optical and mechanical limit switch for focus
- DC Servos for ALC and focus
- Optical sensor switch for five (5) position lens and filter alignment
- Lens wheel solenoid plunger lock for position accuracy
- Stepper motors for filter and lens wheel

Optional

- Lens cap assembly
- Automatic light control sensor module
- Sun sensor
- Wide-field target acquisition finder and camera
- Pan/tilt unit
- Environmental enclosure
- Peltier cooler/heater
- CCD Camera

MMC-MFLO-178 on board electronic including

- Motorola 68300 family microprocessor and CPU board with EPROM operating system
- Communications board with a 2 serial Com ports
- DC servo driver board
- ROM battery backup
- Analog to Digital Conversion board
- Digital I/O board
- Relay Boards
- Pressure sensor
- Temperature sensor
- Voltage sensor
- DC/DC converter and timer board
- Component interconnect board

MMC-MFLO-178 External Components

- 15 foot inter-connect cable
- Interconnect box
- 12 VDC 4.5 Amp output power supply, universal AC input (110 to 240VAC)
- RS 422 converter
- Pentium 133 PC (min), 32 MB Ram, 520Mb Hd, 1.4Mb floppy, 2 serial ports, 17 " monitor
- MMC-MFLO-178 PC Console control software installed. See PC console description.

Optional

- 33.3 modem
- Frame Grabber three channel input (optional)
- Video display card (optional)

Video equipment

Note: The MMC-MFLO-178 System needs to have a video camera to generate video images and a video monitor to display them. Due to individual varying needs of the end user and the unlimited number of cameras available, these items are not included in the base system and must be tailored to suit the end products function. MesaMW will assist the customer in selection of the correct video equipment to meet the desired need and function of the finished product. The MMC-MFLO-178 system hardware and software can support three cameras, which includes the optional Wide Field finder system. Serial and digital controlled cameras can be supported within the software code and will also require additional pre programmed adaptive control codes to be embedded into the control software. The MesaMW optical design will effectively support 1/3", 1/2" and 2/3" chip formats.

Minimum video function display will require a B/W Video camera (12VDC, 1/3") and a 12" B/W 2- channel video monitor.

PC Console for MMC-MFLO-178 Surveillance System

Introduction

The software will be a Windows 95/98 and Visual Basic based system. The new console will combine the video and control functions into a single user-friendly Windows-based PC application. All windows including the live video window will allow resizing and repositioning on the screen. Operator actions will be via keyboard or mouse commands. Keyboard commands will use a top line menu, arrow keys and the enter key to activate most functions. The mouse will also access the top menu bar.

Description of Product

The PC Console hardware will require an IBM PC based system with the following minimum requirements:

PC hardware components

- Intel Pentium 133 MHz Processor Minimum
- 800 by 600 Pixel Super VGA display (LCD Flat Panel or CRT)
- 8 Megabytes DRAM 70 Ns Memory
- 512 MB Hard drive (1 GB Minimum for saving video frames)
- 2RS-232 Communication Ports
- 1 RS-232 to RS-422 Converter external or an internal RS422 card
- 1 Parallel port for printer
- 1 Super VGA Windows accelerated video card with 4 MB Memory
- 1 Mouse or Trackball
- 1 101 key AT Keyboard
- 1 33600 Baud Modem (optional) for long distance communications
- 1 Frame grabber (Win/TV type) (optional) video transmission, video computer enhancement and storage

Software components:

- Communications - Host/controller COM, Pan and Tilt COM, Multiple controllers
- Basic operations - Power up self test, BIT, Error recovery and reset function tests and visual display
- Filter wheel control and display - 5-position max
- Lens wheel control and display - 5-position max
- Focus control and encoder position display
- Parfocal, system parameters
- Store and save user defined positions and motor speed setting
- LC and ALC control and density display
- Pressure - Read and display status, automatic control of gas relay to keep internal pressure at .5 PSI
- Temperature - Read and display status
- Voltage - Read and display status
- One external device relay control (wash)
- Continuous status information and visual display
- Standard multi window operation and display
- System Debug windows, to check current component status and message code
- Bottom screen banner basic status reporting display

Options and Upgrades

- Pan/Tilt integrated control
- Camera switcher control
- Lens cap activation control
- Serial Camera functional control
- Modem control and auto setup
- Sun sensor monitoring
- Video transmission control and display
- Video enhancement control
- Heat/cooler control for user input

The functions accessible via the menu bar will include the following top level and lower level functions:

Scope

- Zoom Control Select 1 of 5
- Filter Control Select 1 of 5
- Speed Settings Zoom and Filter
- Focus Slider Bar
- Focus Speed Setting
- Parfocalization On/Off
- Encoder position display
- Save Parfoc Position
- Light Control/ Auto Control
- Manual/Auto select
- Light/Dark and auto mode threshold setting

- Lens cap control

System

- Addressing and type
- System message display and recording
- System reset
- Scope, Pan/ Tilt, Communication or Video reset
- BIT test and information display
- External relay control
- Lens cap control
- Systems setup and save parameters

Camera

- Select Day/Night (Camera switcher option)
- Select Camera/Finder (both cameras must be serial controlled)
- Brightness (Must be a serial controlled camera)
- Color Balance (Must be a serial controlled camera)
- Gain (Must be a serial controlled camera)
- Integration (Must be a serial controlled camera)
- Note this area will vary according to serial camera options

Pan and Tilt (Pan/Tilt required)

- Up/Down arrows buttons
- Press or hold ramp to speed function and center stop buttons
- Set reference Alt/AZ position
- Set altitude for range calculations
- Position readout
- Home
- Set Home
- 5 user defined preset positions
- Set Speed
- Directional pointing compass representation
- Compass point, click and go function
- GoTo command functions

Video (Frame grabber required) under development

- Video display control (Up to three active video windows)
- Color
- Brightness
- Contrast
- Freeze
- Capture
- Store
- Print
- Pixel Zoom
- Filter
- Low Pass
- High Pass
- Edge Detect
- Crosshair

The frame grabber will be of such a type as to allow full color video display for up to 30 frames per second without interfering with normal graphic operations. MesaMW has a library of video functions, which will be used for development of the software. The frame grabber will require a minimum of 2 switchable inputs ideal for camera switching or a single camera and the finder. More boards can be used simultaneously allowing multiple sensors to be viewed from one station (Higher resolution PC displays should be used).

Tele Communications (Modem and transmission software required) Underdevelopment

- setup, auto test
- Phone line test and select
- Baud rate select
- Modem Select/Commands (Far range)
- Serial port select (Near range)

Communications will be set up to work directly via a modem (Com 2) attached to dedicated phone lines. This will allow remote access to the MMC-MFLO-178 system local control computer. The user will dial up the remote computer and log on via the installed modem. The local control computer will then send information via the RS422 line to the MMC-MFLO-178 system. RS-422 Communications to scope and equipment will provide longer-range access, an RS-232 to RS-422 converter is attached to the RS-232 port (Com 1) will provide operation of MMC-MFLO-178 and Pan Unit. An isolating RS-422 converter internal or external will be required.

General System Requirements for MMC-MFLO-178

Minimum Computer requirement (Host)

- Intel Pentium 133 MHz Processor
- 800 by 600 Pixel Super VGA display (LCD Flat Panel or CRT)
- 32 Megabytes DRAM 70 Ns Memory
- 512 MB Hard drive (1 GB Minimum for saving video frames)
- 2 RS-232 Communication Ports (com1 and com 2)
- 1 Parallel port for printer
- 1 Super VGA Windows PCI or AGP video card with 4 MB Memory
- 1 Mouse or Trackball
- 1 101 key AT Keyboard
- Windows 95/98 operating system

Minimum Communication requirement (Host)

- 2- D type 9 pin RS 232 serial COM line

The serial communications setting are:

- ◆ 9600 Baud
- ◆ 8 Data Bits
- ◆ 1 Stop Bit
- ◆ No Parity

If using an internal RS422 card, same as above and

- ◆ RS-422A Full Duplex Communications

The MMC-MFLO-178 system can be configured RS232 or RS 422. **RS422 is the standard configuration.**

Basic communication description

Serial Communications is based on a client/server type serial interface. The host server must request information from a particular scope or pan unit and then that unit responds. Using this technology and RS-422 communications protocol, a simple multi-drop system was developed to allow multiple scopes and pans to be interconnected and accessed via a single host controller. The processor gives highest priority to serial communications and a special "BREAK" code allows the system to clear itself in case of an inadvertent lock-up. Coupled with a complete error checking/recover suite in software, the system will always fight to re-establish communications.

Messages are passed between the host and scope units via packets. The packets contain source and destination addresses to allow multiple hosts to access multiple scopes. Each packet contains a leading character and a trailing character to delineate the packet. An additive checksum is also part of the packet. Contained in the packet is a sequence number, which allows scope units to inform the host of a particular packet, being lost. The scope and pan units monitor a noise pulse accumulator built into the hardware serial chips and at a predetermined level, alerts the host console of a noisy line. This allows the system administrator to correct noisy line problems before the system degrades unacceptably.

An isolator can be provided at the remote site to keep stray grounding problems from corrupting the data.

The RS-422 signal should be split to the Pan and Scope unit's one side of the isolator while the other side returns to the host system. Some systems have this installed at the factory.

SCOPE AND PAN UNIT					INTERFACE BOX				PC CARD RS422			
CPU	SCOPE		PAN	16 PIN	CABLE 1:1	16 PIN	DB-9	12 PIN	CABLE	COM	PIN	SIGN
SIGN	PIN	DB-9	DB-9	M/F	SZ/PAN	M/F	M/F					
TX+	3	2	2	B	B:B	B	9	B	B:9	9	9	RD B (+)
TX-	4	7	7	A	A:A	A	1	A	A:1	1	1	RD A (-)
GND	5	3	3	E	E:E	E	5	E	E:5	5	5	GND
RX-	7	4	4	C	C:C	C	3	C	C:3	3	3	TD A (-)
RX+	8	9	9	D	D:D	D	2	D	D:2	2	2	TD B (+)

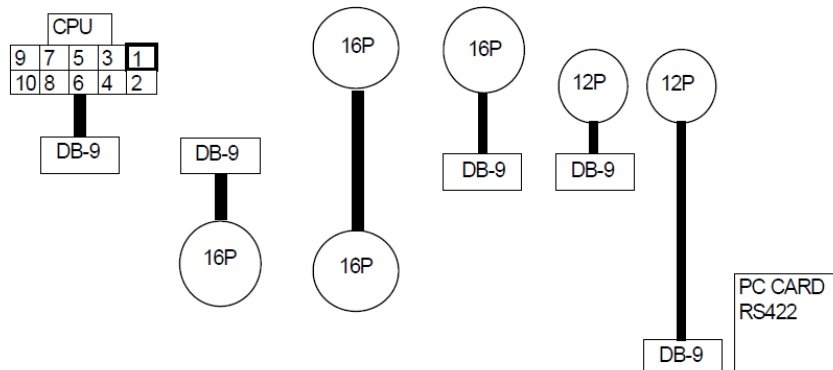

Please review the above chart for basic system communication outline

Minimum Camera requirement

- Standard Analog RS170 high-resolution black & white CCD camera with ½ to 1” detector preferred.
- 12Volts DC will be required to utilize internal system power.

Minimum Power requirement

- 12 volts DC 4.5 Amp regulated low ripple and noise power supply for SZ182 unit
- 24 volt DC 8 Amp power supply for Cooler and heater units
- 24 volts DC 30 Amp power supply for Pan/ Tilt unit
- **Systems equipped with pre-wired DC power supplies inside Interface boxes must specify input AC voltage 120/240 VAC and the frequency.**

Minimum Support and Site Preparation requirement

See specifications for approximate weight of items and the following diagrams for locations of mounting holes. If this is a permanent site installation the site should be prepared for system mounting. Piers, mounting flanges and adapter plate should be manufactured as per mounting hole specification. Power, video and communication wiring should be in place ready for connection to MMC-MFLO-178 system. Communication and video wire must be run into control area for connection to control console PC. Please review the following pages to get a better understanding of possible configurations Each system may be different, these issues must be discussed prior to shipment. The support must be adequate to hold steady. Vibration will degrade video images. The more massive the tripod or supporting structures the better.

MMC-MFLO-178 Mounting

The MMC-MFLO-178 will attach to ¼-20 and 3/8-16 threaded studs. There are several rows along the bottom plate to allow proper balance on top of a heavy tripod. The MMC-MFLO-178 Enclosure is designed to mount directly to the Pan/Tilt unit. If purchasing without Pan/Tilt unit you must specify a hole pattern. Please refer to sample diagram for basic size and locations of connectors on next page. If you have special hole pattern requirements they can be added.

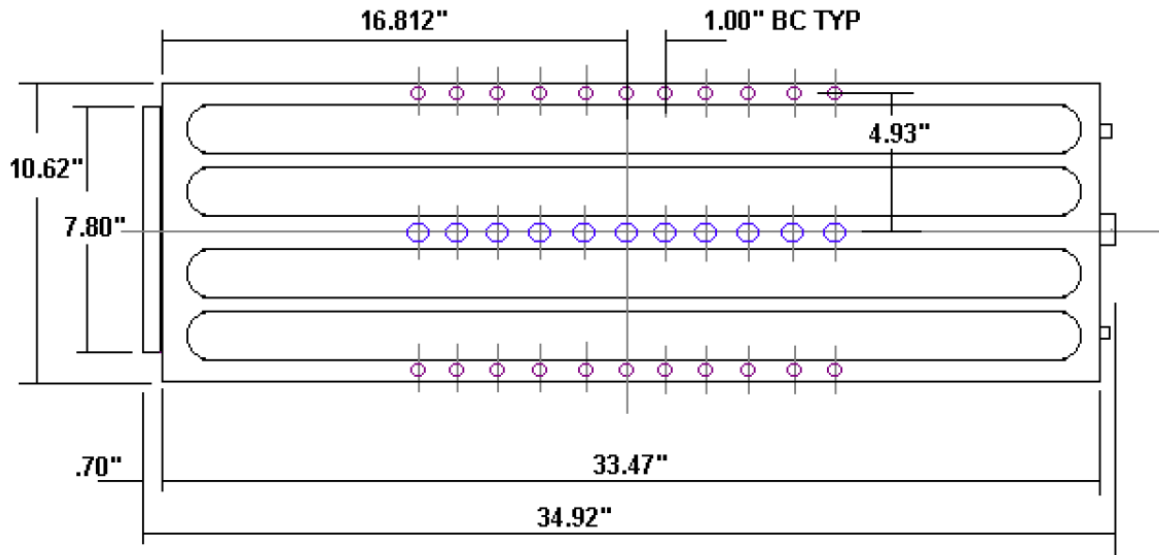

MMC-MFLO-178 Base Plate No Enclosure.

Sample enclosure base plate.

The enclosure base plate can be adapted to suite individual needs please contact MesaMW for your requirements. All enclosure base plates will be configured to connect to the Pan/Tilt unit.

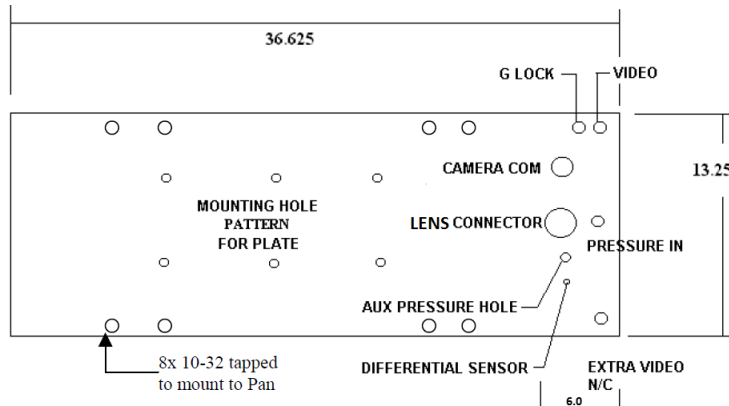

- Mounting Holes D & Bottom TAP 3/8-24
- Pressure in – Regulated pressure through solenoid shut off valve.
- Aux Pressure – Un regulated inside pressure access can Input or Read via air gauge.
- Differential – is connected to differential sensor inside to read pressure inside enclosure.
- Lens Connector – Power and communication to MMC-MFLO-178 electronics.
- Camera Connection – to control of camera RS422.

Pan and Tilt Mounting

The Pan/ Tilt Unit has 1/2-13 threaded holes to allow mounting to a ringed pier or round adapter plate. Special mounting requirements can be tailored to suite individual needs. See the next few pages for some examples of possible configurations and mounting solutions.

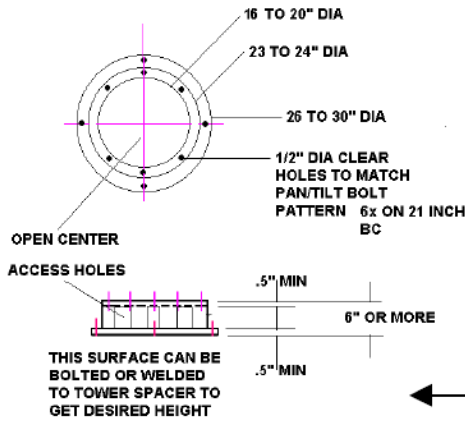
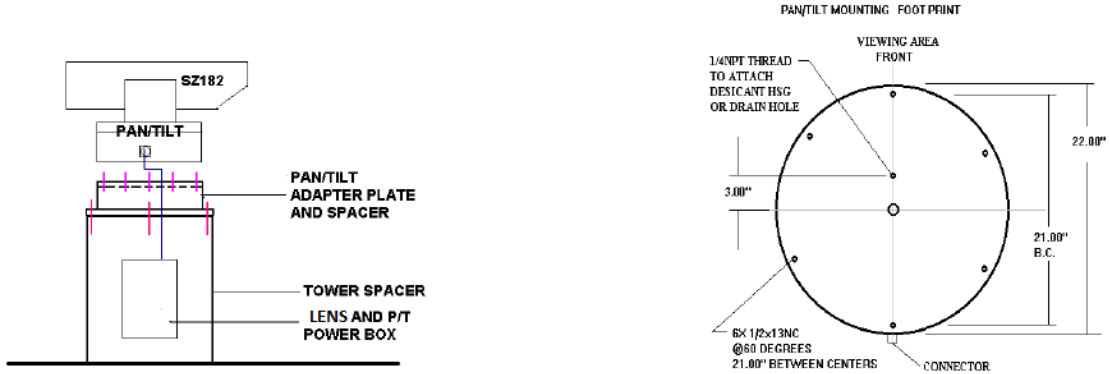

BOTTOM VIEW OF PAN UNIT WITH STANDARD MOUNTING HOLE

SAMPLE ADAPTER RING TO FIXED MOUNTING COLUMN

OVERALL SYSTEM DIMENSIONS THIS IS FOR REFERNECE ONLY

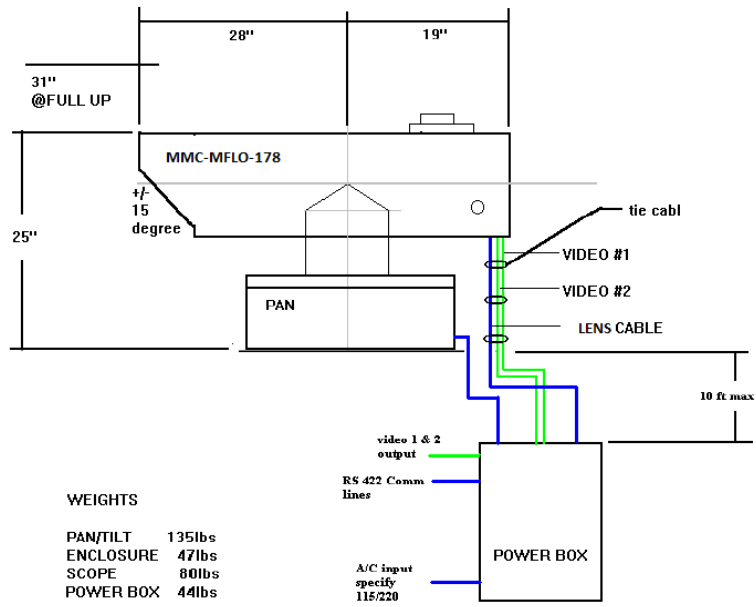

System Setup and Cable Interconnection

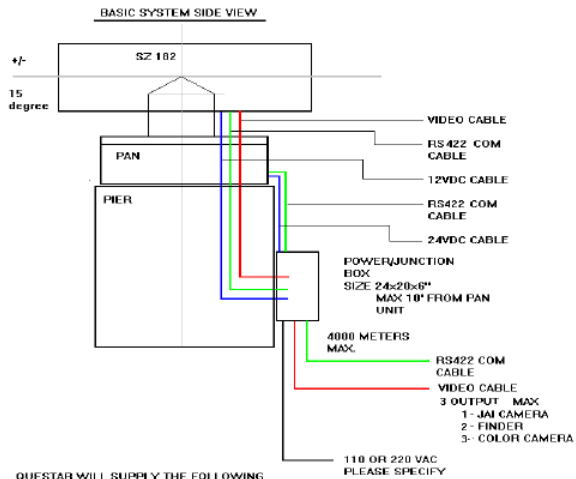

QUESTAR WILL SUPPLY THE FOLLOWING

- POWERJUNCTION BOX
- POWER AND CONTROL CABLES FROM PAN/TILT AND LENS TO POWERJUNCTION BOX

CUSTOMER

- VIDEO CABLE FROM SCOPE TO JUNCTION BOX AND ALL OTHER CABLES FROM CONTROL STATION BY CUSTOMER
- HIGH QUALITY VIDEO AND COMMUNICATION CABLES WITH SHIELDS MUST BE USED.
- POWER CABLES CAN NOT BE RUN IN SAME CONDUIT WITH ABOVE CABLES
- COM CABLES SHOULD BE LOW IMPEDENCE INDIVIDUALLY SHIELDED TWISTED PAIRED (MIN 2 PAIRS AND A GROUND)

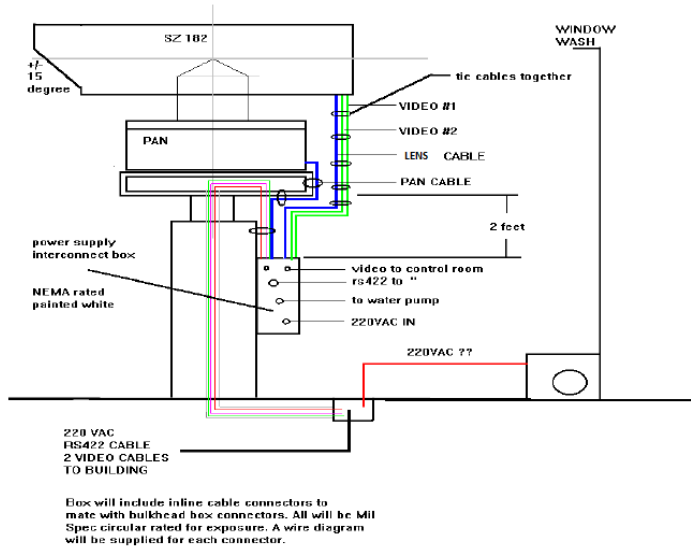
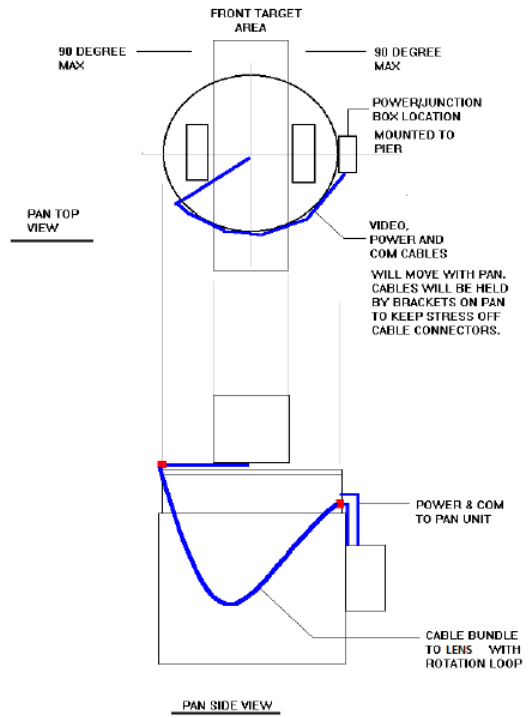

Box will include inline cable connectors to mate with bulkhead box connectors. All will be MIL Spec circular rated for exposure. A wire diagram will be supplied for each connector.

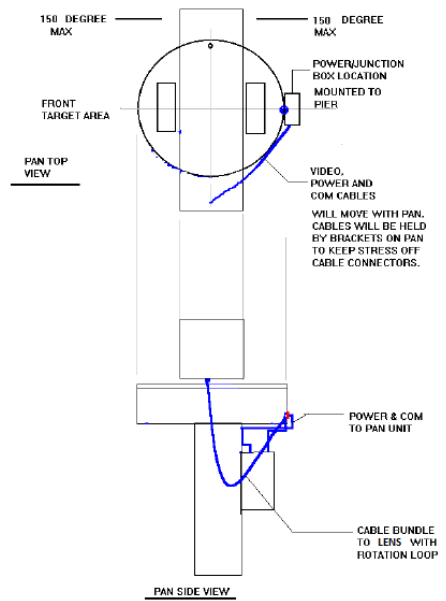

Sample Control Windows

